

AUTOMATIC ROOM TEMPERATURE CONTROLLED FAN SPEED CONTROLLER USING PT-100

M. A. A. Mashud^{*}, Dilruba Yasmin, M. A. Razzaque and M. H. Uddin

Abstract— Now-a-day's technology is running with time, it completely occupied the life style of human beings. Even though there is such an importance for technology in our routine life there are even people whose life styles are very far to this well known term technology. So it is our responsibility to design few reliable systems which can be even efficiently used by them. Automatic Room Temperature Controlled Fan Speed Controller is one of them. The developed system provides an environment in which no user needed to control the fan speed. Automatically control the fan speed by sensing the room temperature. These fascinating efforts to create intelligent system are to provide human being a more convenient life. The circuit was designed using electronic components available in local market to keep the cost at low level.

Index Terms— PT-100, Room Temperature, Home Automation, Fan Speed, Low-cost

1 INTRODUCTION

SINCE the weather changes rapidly in the world, the temperature changes frequently. Temperature monitoring and control is important in industrial environments and also in the human living room. Industrial temperature monitoring is important in many applications and systems as excessive changes in the temperature can lead to detrimental effects and failure of operation [1-2]. Many important devices and chip components, such as integrated circuit, demand for stable temperature and voltage without instantaneous breakdown and wide range fluctuation. Early detection of overheating and proper handling of such situation is essential [3] to avoid deterioration and faulty components. Thermal management in the semiconductor electronic industry is facing increasing challenges due to increasing power and cost effective solutions [4]. Due to the excessive changes of temperature human life being harmful. In the electronics world we want to make the human life comfortable. Therefore the home automation system is very essential. Fan speed controller is one of the parts of the home automation system.

In the case of home automation system, room temperature monitoring is very important. Sensors are widely used for measurement of temperature. Usually, a temperature sensor converts the temperature into an equivalent voltage output. PT-100 is such a sensor. Here we describe a simple temperature controlled fan speed controller which being popular because of simple

circuitry and low cost.

2 SYSTEM DESIGN

The system is divided into six main parts, namely, the low-voltage power supply, fixed voltage circuit, sensor & driver circuit, subtraction circuit, buffer circuit and fan dimmer circuit. The sensor & driver circuit consists with PT-100 temperature sensor with associative circuits. The output of the sensor is converted in volts and it use as input of subtraction circuit also the output of fixed voltage circuit is applied to the input of subtraction circuit. The output of subtraction circuit controls the fan dimmer via buffer. The block diagram of the proposed system is depicted in Fig. 1. The complete circuit diagram of the proposed system is shown in Fig. 2.

2.1 Low-Voltage Power Supply

The low-voltage power supply unit consists of transformer X, diode D₁, D₂ and capacitor C₁ [5]. The output of this unit is +12 volt dc which is denoted by +12V.

2.2 Fixed Voltage Circuit

Fixed voltage circuit consists of resistor R₁, Zener diode Z₁, variable resistor VR₁, VR₂, VR₃ and IC₁ [6-7]. In this circuit Zener diode acts as a voltage regulator and IC₁ works as a unity follower or buffer circuit.

2.3 PT-100 Sensor & Driver Circuit

PT-100 sensor and driver circuit consists of diode D₁, Zener diode Z₂, resistor R₂-R₅, variable resistor VR₄, VR₅, transistor Q₁, Sensor PT-100 and IC₂. In this circuit transistor Q₁ works as a constant current source to drive the sensor PT-100. Here IC₂ works as a buffer to avoid the impedance mismatching.

2.4 Subtraction Circuit

- M. A. A. Mashud is an Assistant Professor, Dept. of Applied Physics, Electronics & Communication Engineering in Islamic University, Bangladesh, PH-0088 01716486590. E-mail: mashud@aece.iu.ac.bd
- Dilruba Yasmin is a Lecturer, Dept. of Physics, Katlagari Degree College, Jhenaidah, Bangladesh.
- M. A. Razzaque is an Assistant Professor, Dept. of Applied Physics, Electronics & Communication Engineering in Islamic University, Bangladesh
- M. H. Uddin Dept. of Materials Science, Graduate School of Engineering, Osaka Prefecture University, 1-1 Gakuen-cho, Naka-ku, Sakai, Osaka 599-8531, Japan

The subtraction circuit consists of IC3, resistor $R_6 - R_9$ and variable resistor VR6 [8]. Here VR6 is used to null the offset of this subtraction circuit.

2.5 Buffer Circuit

The buffer circuit consists of IC4 with VR7. Here VR7 set the null offset of the output [9].

2.6 Fan Dimmer

The fan dimmer circuit consists of resistor R_{10} , R_{11} , opto-coupler, capacitor C_2 , triac 477DB and SCR TLC226B and fan. Here resistor R_{10} is used to limit the output current of the buffer circuit.

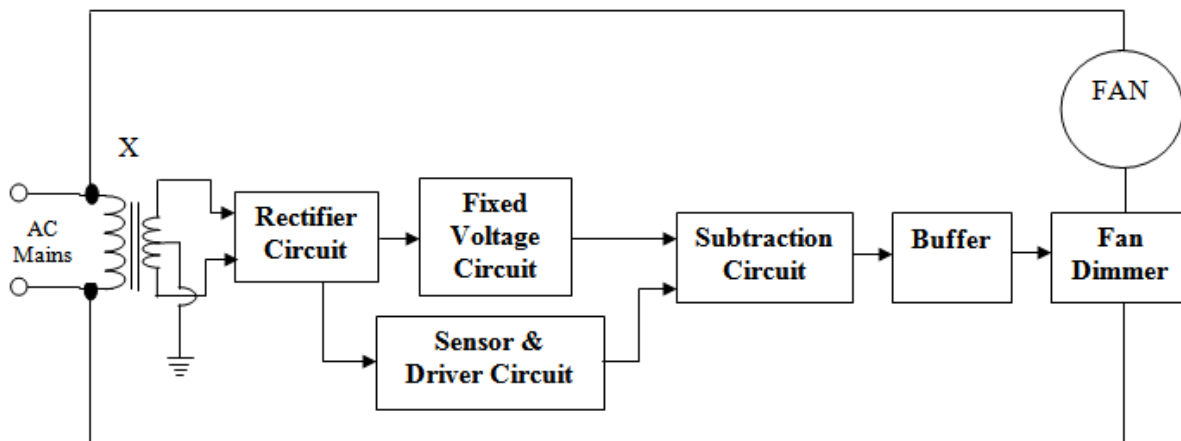

Fig. 1 Simplified Block Diagram of the Proposed System

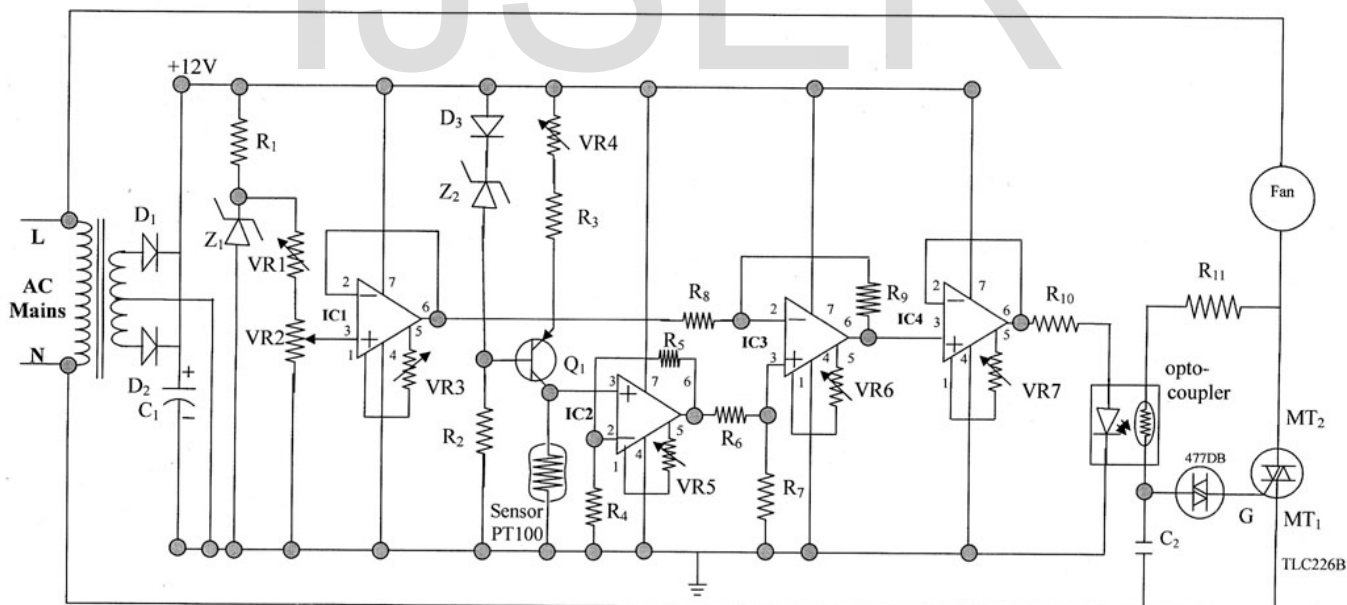

Fig. 2 Circuit Diagram of the Proposed System

3 RESULTS AND DISCUSSION

The device was successfully designed and developed, as its performance was strong. The device employed a

locally readable components and PT-100 sensor. The low voltage power supply unit was designed to supply the low voltage all over the system.

The fixed voltage power supply unit was designed for highly regulated output to use as a reference voltage of this circuit. In this design we had varied the input ac voltage from 198 volt to 248 volt but the output was remain constant at 6.2 volt DC. The output waveform of this unit is depicted in Fig. 3.

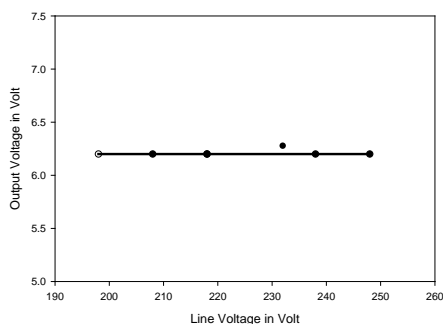

Fig. 3 Output of fixed voltage unit

The resistance temperature equation of PT-100 sensor is as follows:

$$R_t = R_0 (1 + \alpha T)$$

$$= 100(1 + 0.00392T)$$

Using this equation each calculated and measured resistance R_T is recorded for each settings temperature. Plot a graph for temperature vs resistance is depicted in Fig. 4. From the graph we observed that the resistance of the PT-100 is directly proportional to the temperature.

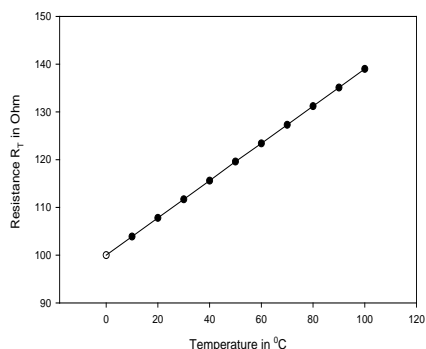

Fig. 4 Graph for temperature vs resistance

We have ascertaining the developed device in a series of test and we observed sound performance. We have recorded the calculated and measured value of temperature and plot a graph as depicted in Fig. 5. From the graph we see that the practically measured value are

calculated value of temperature of this device is exactly same. So the device will perform better.

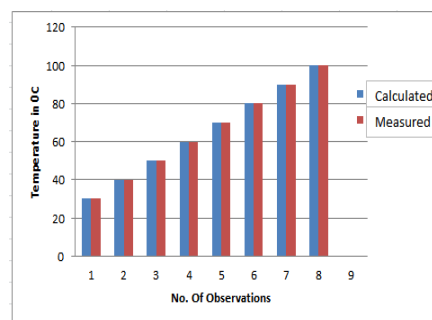

Fig. 5 Graph for comparison of temperature

The developed device has a facility to set the starting value of the fan. We have seen that the fan speed is directly proportional to the room temperature. The graph is depicted in Fig. 6. It is seen that when the room temperature is high the fan speed is high and vice-versa.

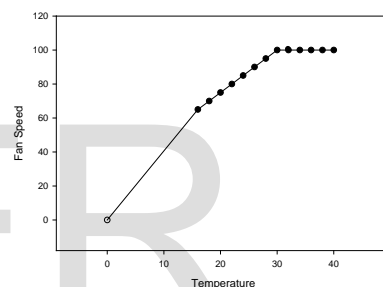

Fig. 6 Graph for temperature vs fan speed

In recent times, the cost of electronic equipment has fallen significantly, though automated equipment remains expensive. However due to the rapid development of electronics, all designed components and instruments are inexpensive. Moreover, when the features of the presently used device are compared with the developed device, the latter emerges as a better choice in terms of cost, portability and design. Particularly in developing countries, the use of the deigned instruments will be accessible for many users.

4 CONCLUSIONS

The automatic room temperature controlled fan speed controller unit was put under a series of tests for ascertaining its performance as a controller device and very satisfactory results were obtained. This device was also found to be sufficiently quick, so that the safety of the equipment protection by the device under any undesired transient condition of the main supply is

ensured. This device has a very high sensitivity. It is also simple in design, reliable in operation and cost competitive with any other product available in the market. From the above analysis, it is concluded that this device can easily control the fan automatically based on room temperature.

REFERENCES

- [1] Liu, Y., Zeng, J. and Wang, C. (2009). Temperature Monitoring in Laser Assisted Polymer Bonding for MEMS Packaging Using a Thin Film Sensor Array, IEEE Sensors Applications Symposium, New Orleans, LA, USA.
- [2] Jung, W., You, J. and Won, S. (2008). Temperature Monitoring System for Inductive Heater Oven (pp.1734-1737), International Conference on Control, Automation and Systems, Seoul Korea.
- [3] Chiueh, H., Choma, J. and Draper, J. (2000). Implementation of a Temperature Monitoring Interface Circuit for PowerPC Systems (pp.98-101), Proceedings of the 43rd Midwest Symposium on Circuits and Systems, Lansing MI, USA.
- [4] Kuan, Y., Hsueh, Y., Lien, H. and Chen, W. (2006). Integrating Computational Fluid Dynamics and Neural Networks to predict Temperature Distribution of the Semiconductor Chip with Multi-heat Sources, Lecture Notes in Computer Science 3973 (pp. 1005-1013), SpringerVerlag.
- [5] Mehta V. K and Mehta R. (2007). Principle of Electronics, S. Chand & Company Ltd. New Delhi, 438
- [6] Theraja B. L and Theraja A. K. (2002). A Textbook of Electrical Technology, S. Chand & Company Ltd. New Delhi, 2105
- [7] Gayakwad R. A. (2004). Op-Amps and Linear Integrated Circuits, Pearson Edition (Singapore) Pte. Ltd., New Delhi, India, 315
- [8] Mashud M. A. A, Barman S. C, Bhuiyan M. R. A, Islam Md. Serajul. (2013). Design and Implementation of Three Phase Unbalanced Voltage Motor Controller (pp.35-42), IJ. Intelligent Systems and Applications.
- [9] Mashud M. A. A, Uddin M. H and Islam Md. Serajul. (2014). Design and Implementation of Microcontroller Based Digital Soil pH Meter (pp.31-35), ULAB Journal of Science and Engineering

IJSER